

HEAVY DUTY MECHANICAL BEARING ROTATE

- Best Off-Center Load Capacity
- Easy manual Rotation
- Pneumatic Brake Is Standard
- Capacity Of 6,000 Pounds

MODEL NO. *	DIMENSIONS (in.)		WEIGHT (lbs.)
	A	B	
MR6-3636	36	36	480
MR6-5048	50	48	750
MR6-5650	56	50	810

* OTHER SIZES AVAILABLE. CONSULT FACTORY.

AIR CASTER EQUIPPED ROTATES

- Lowest Force Needed For Rotation
- Automatically Locks In Place When Air Is Off
- Very Low Maintenance
- Limited Off-Center Load Capacity
- Capacity Of 6,000 Pounds

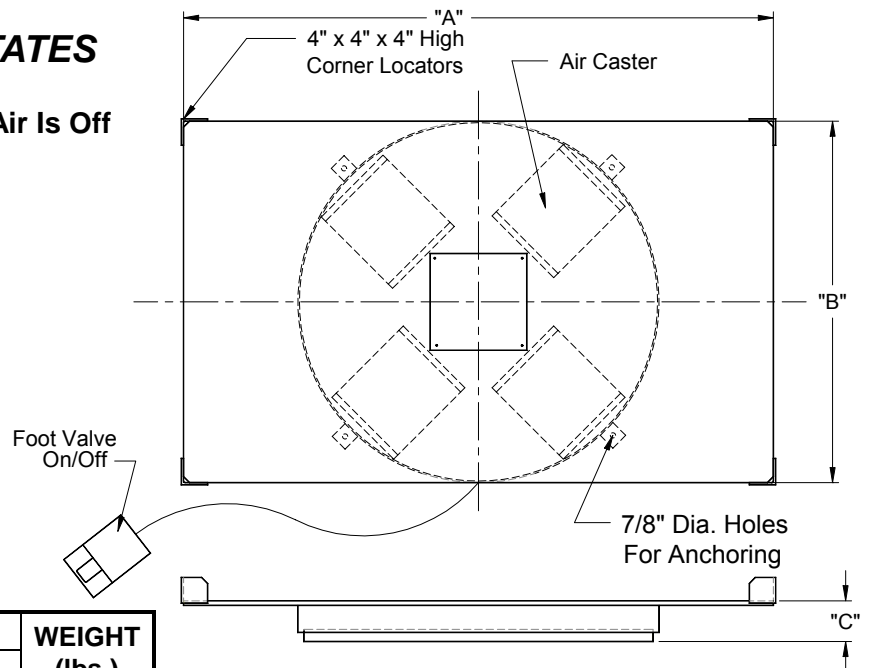

MODEL NO. *	DIMENSIONS (in.)			WEIGHT (lbs.)
	A	B	C	
AR6-4846	48	46	4 $\frac{1}{8}$	450
AR6-5648	56	48	4 $\frac{1}{8}$	570
AR6-9860	98	60	6 $\frac{3}{4}$	2,120
AR6-11072	110	72	6 $\frac{3}{4}$	2,760
AR6-11078	110	78	6 $\frac{3}{4}$	2,970

* OTHER SIZES AVAILABLE. CONSULT FACTORY.