

Plant air operated.  
Requires 85 psi for  
maximum rated load.

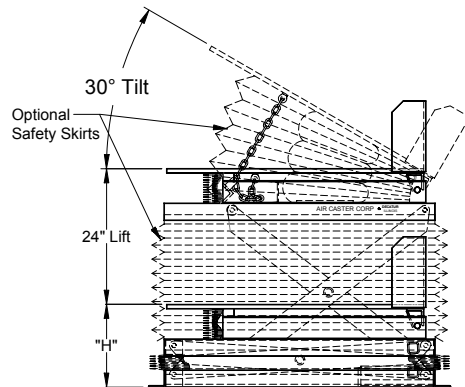
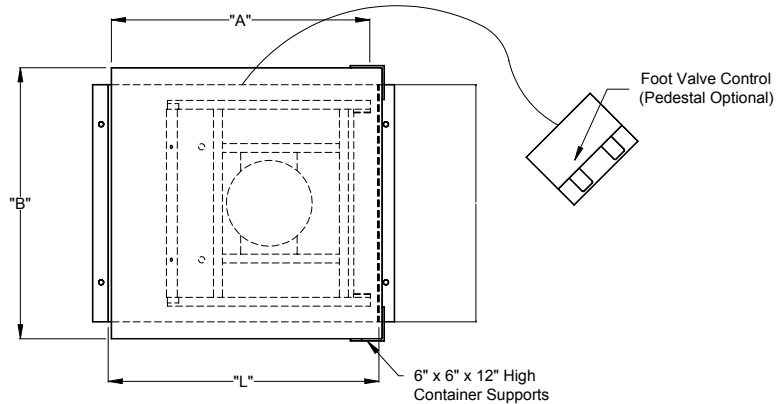

### FEATURES

- Permanently lubricated lift pins
- Serviceable cam follower type roller
- Dual, high strengthened restraint chains on tilter
- Optional tilt deck dampener
- Floor anchor holes in lift base

## PNEUMATIC LIFT and TILTS

MODEL NO.	CAPACITY POUNDS	DECK SIZE (IN.)		BASE SIZE (IN.)		LOWERED HEIGHT	WEIGHT POUNDS
		A	B	L	W		
LT2-3636	2,000	36	36	42	25	14¾	1,090
LT2-4648	2,000	46	48	48	42	14¾	1,350
LT2-4856	2,000	48	56	48	42	14¾	1,470
LT4-4648	4,000	46	48	48	42	14¾	1,450
LT4-4856	4,000	48	56	48	42	14¾	1,590
LT6-4648	6,000	46	48	56	48	16¼	1,500
LT6-4856	6,000	48	56	56	48	16¼	1,620

## LOW HEIGHT PNEUMATIC LIFT and TILTS

MODEL NO.	CAPACITY POUNDS	DECK SIZE (IN.)		BASE SIZE (IN.)		LOWERED HEIGHT	WEIGHT POUNDS
		A	B	L	W		
LT2-3636LH	1,500	36	36	44	24½	9⅞	780
LT2-4648LH	1,500	46	48	44	24½	9⅞	990
LT4-4648LH	3,500	46	48	44	39	9⅞	1110
LT4-4856LH	3,500	48	56	44	39	9⅞	1170

### ACCESSORIES

*Safety Skirt* - Wire reinforced accordion safety skirt for both lift and tilt sections available.

*Safety Pilot Operated Check Valve* - This check valve will prevent the lift or tilt from lowering in the event of a ruptured or severed air hose. One required for both lift and tilt. To order specify *Check Valve No. CV-38*.