

Plant air operated.
Requires 85 psi for
maximum rated load.

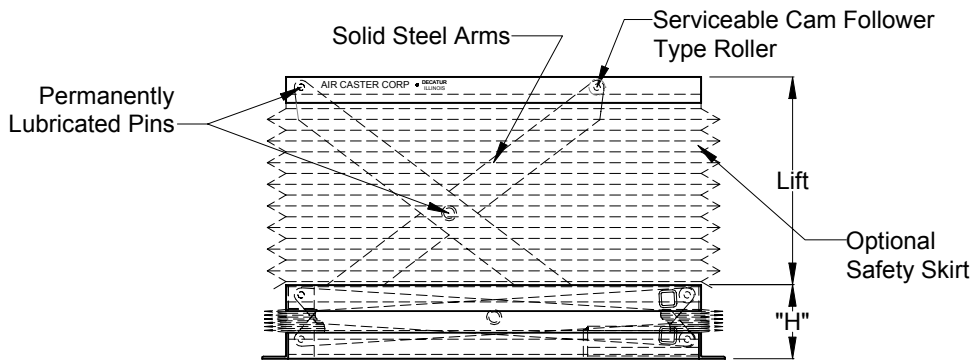

OFFERING - PNEUMATIC LIFTS

MODEL NO.	CAPACITY POUNDS	TOP SIZE (in.)		LOWERED HEIGHT	LIFT (in.)	WT. POUNDS
		L	W			
2-ASL-2536	2,000	36	25	8½	20	370
2-ASL-2542	2,000	42	25	8½	24	400
2-ASL-2548	2,000	48	25	8½	24	445
2-ASL-4248	2,000	48	42	8½	24	585
4-ASL-2548	4,000	48	25	8	20	510
4-ASL-4248	4,000	48	42	8½	24	615
6-ASL-4856	6,000	56	48	10	24	720

OFFERING - LOW HEIGHT PNEUMATIC LIFTS

MODEL NO.	CAPACITY POUNDS	TOP SIZE (in.)		LOWERED HEIGHT	LIFT (in.)	WT. POUNDS
		L	W			
2-ASL-2444LH	2,000	44	24½	4⅞	24	410
2-ASL-4144LH	4,000	44	41	4⅞	24	525

ACCESSORIES

Safety Skirt - Wire reinforced accordion safety skirt for four (4) sides of lift. **Safety Pilot Operated Check Valve** - This check valve will prevent the lift from lowering in the event of a ruptured or severed air hose. To order specify **Check Valve No. CV-38**.